

Skip Loader

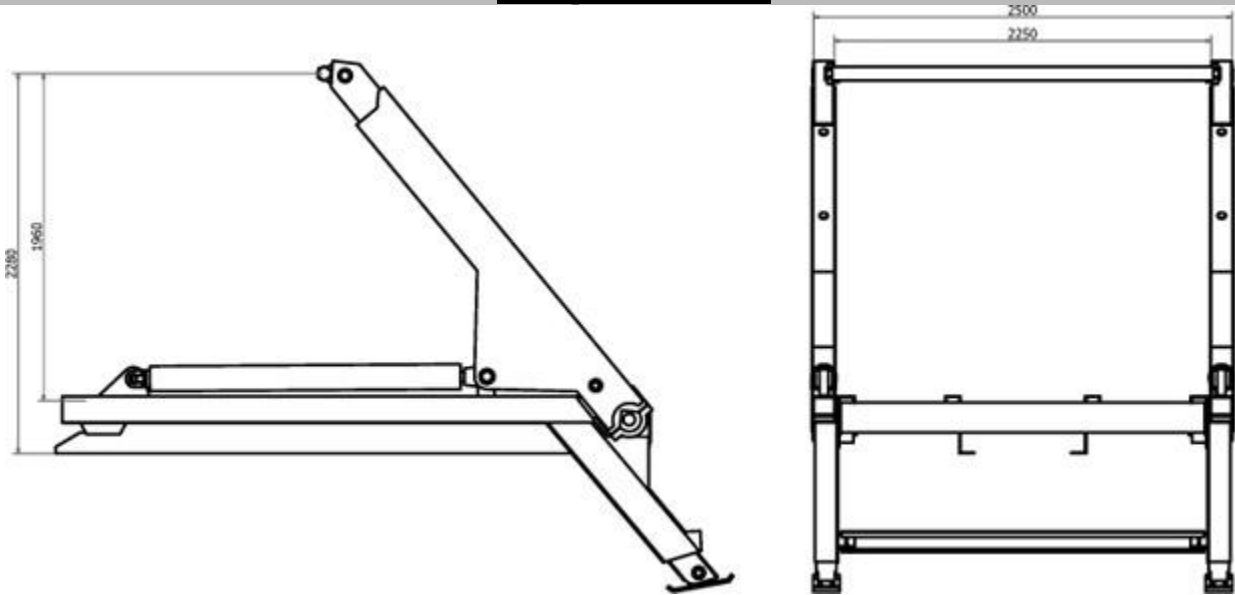

TECHNICAL SPECIFICATIONS

System needs:	Pick up & dump the load into containers
Load & capacities :	Available in 10, 15,20,25 tons load – volume 5,10,15 m3
Control:	Manual operation out cabin & electro/hydraulic inside cabin
Weight and capacity :	<p>Weight without options and accessories: 2550kg - incl.</p> <p>All options and accessories: 2900kg</p> <p>Capacity floor /retracted arm: 15'300kg</p> <p>Floor / long arm: 11,000kg</p> <p>Underneath floor /retracted arm 10,500kg</p> <p>Underneath floor / long arm 7,000kg</p> <p>Chassis recommended wheelbase: 3600-4200mm</p> <p>Recommended gross vehicle weight: 20,000kg</p> <p>Hydraulics /PTO power take off (gear ratio»1) >300 Nm</p> <p>Recommended pump 60 l/min, 300 bar</p>