

Crane Telescopic

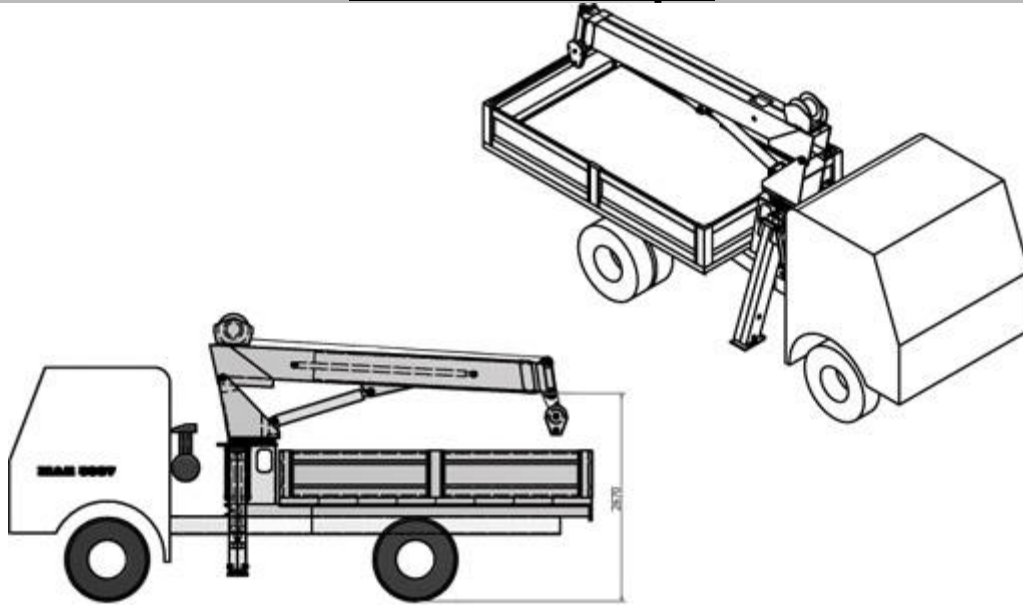

TECHNICAL SPECIFICATIONS

For many different application such as water & sewerage service 10 hours/day of hard work you need such a crane like ours ATTAYA TTL series.

Product capacities starting from 10 tm up to 50 tm fully hydraulic control in both truck sides.

Vertical and horizontal hydraulic control for crane stabilizers.

ATTAYA telescopic cranes comes in 2,3 and 4 telescopic booms up to 12 meters length.

Rope hoist up to 6 ton capacity with 30 meters length.

Continues rotation 360 degrees2 sides hydraulic control.

Hydraulic system equipped with suction and pressure oil filter.

Hydraulic piston pump start from 40 L/m up to 80 L/m.

Working pressure up to 300 bars.

Safety valves on all cylinders movement.