

HOT LINE INSULATOR WASHER

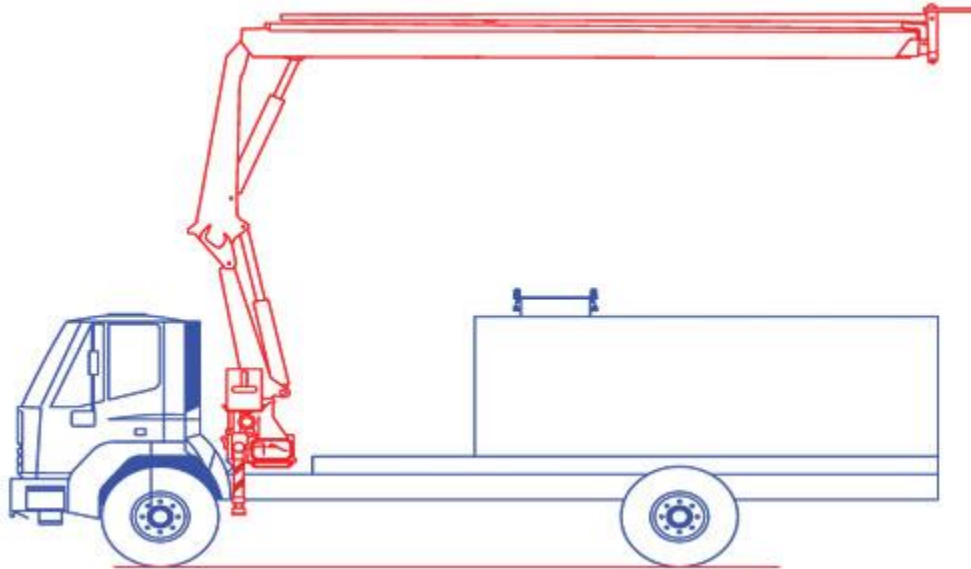

TECHNICAL SPECIFICATIONS

Recommended truck :	3 axles 6x6 driven
Boom:	available in two versions articulated or telescopic from 15 up to 40 meters height, 360 degrees Rotation and 90 degrees vertical & horizontal position.
Truck stability:	4 outriggers fully hydraulic control in order to secure the truck during system operation.
Washing system:	<p>Shutting nozzle: available in 6, 7, 8 and 9 mm made of stainless steel grade 316 connected to the delivery high pressure hose with 1" diameter mounted on automatic reel.</p> <p>High pressure plunger water pump with throttling valve operated with suitable diesel engine in order to reach 200 bars.</p> <p>System including water filter in the suction line and has flow capacity up to 200 liters/min. with safety valve on pressure line.</p> <p>The pumping system operated by diesel engine with control panel.</p> <p>Control panel for operate and shut off the pressure pump in addition to the flow, pressure, crane movement.</p> <p>System equipped with water tank capacity up to 10m³ available in still or stainless version.</p> <p>The truck watering system is equipped with earth cable in two points mounted on cable reel.</p>